

Harlequin Liberty Permanent Sprung Floor Panels

Permanent installation of Liberty panels.

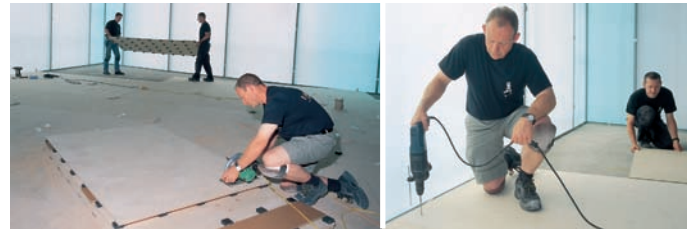

Rolling out the dance vinyl

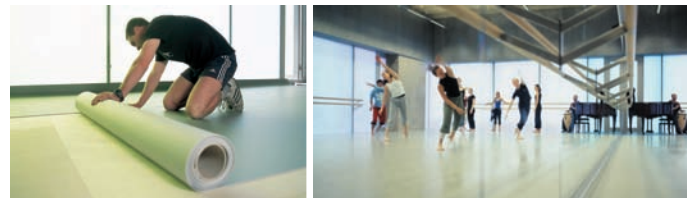

Installation of Liberty panels at Laban, London.

Harlequin Liberty Portable Sprung Floor Panels



Installation of Harlequin Liberty portable panels at The Royal Albert Hall, London



Harlequin Liberty is a modular floor manufactured from engineered panels with elastomer blocks located at regular intervals on the underside. Panels are laid brickwork on the sub-floor so that cross-joins do not coincide. They are linked to each other by a radiused tongue and groove pivot joint and secured by means of a unique locking system which removes the need to fix the panels mechanically to the sub-floor.

British Harlequin plc
Festival House, Chapman Way
Tunbridge Wells, Kent TN2 3EF
Tel. 01892 514 888
Fax 01892 514 222
Freephone 0800 28 99 32
www.harlequinfloors.com
enquiries@harlequinfloors.com

Harlequin Europe SA
29, rue Notre-Dame
L-2240 Luxembourg
Tel. +352 46 44 22
Tel. FR +352 46 44 99
Tel. DE +352 46 39 39
Free phone 008 009 069 1000
Fax +352 46 44 40
www.harlequinfloors.com
info@harlequinfloors.com

American Harlequin Corporation
1531 Glen Avenue, Moorestown
NJ 08057, USA
Tel. +1 (1) 856 234 5505
Toll Free in USA 800 642 6440
Fax +1 (1) 856 231 4403
www.harlequinfloors.com
dance@harlequinfloors.com

Harlequin Australasia Pty Ltd.
PO Box 1028, 36A Langston Place
Epping, NSW 1710, Australia
Tel. +61 (2) 9869 4566
AUS Freecall 1300 666 900
Fax +61 (2) 9869 4547
www.harlequinfloors.com
contact@harlequinfloors.com

Harlequin Asia Limited
1801 The Strand
49 Bonham Strand, Sheung Wan
Hong Kong
Tel: +852 254 11 666
Fax: +852 254 11 999
www.harlequinfloors.com
hksales@harlequinfloors.com

LONDON
LUXEMBOURG
LOS ANGELES
PHILADELPHIA
FORT WORTH
SYDNEY
HONG KONG

Panels layout

Liberty panels with Cascade surface at the Schweizerische Ballettberufsschule, Zürich, Switzerland

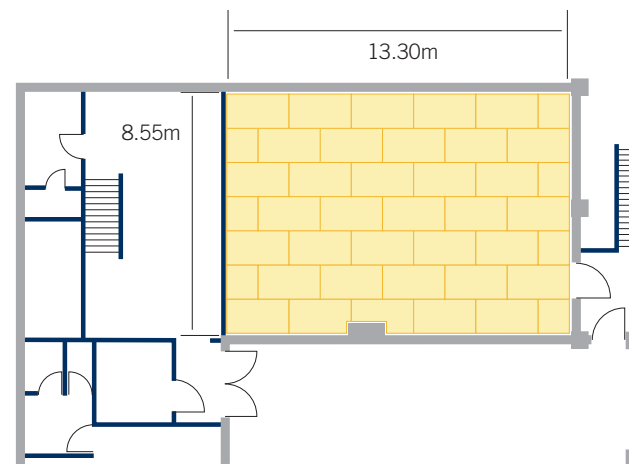

SPECIFICATION GUIDE

Harlequin Liberty Permanent & Portable Sprung Floor Panels

Dimensions:	Full size panel 2m x 1m (78" x 39") Half size panel 1m x 1m (39" x 39") Other panel sizes available to order
Weight:	Permanent panels 25 kg (55 lbs); Portable panels 35 kg (77 lbs)
Installed Thickness:	Permanent panels 37mm (1 1/2"); Portable panels 42mm (1 5/8") plus the Harlequin floor
Installation Time:	Permanent panels approx. 100 sq.m. (120 sq.yd.) per day with 2 persons Portable panels approx. 100 sq.m. (120 sq.yd.) per hour with 2 persons
Thermal Conductivity:	Ply 0.14 W/m K (k values); Vinyl 0.067 W/m K Further values may need to be taken into account for the elastomer blocks and air space
Maximum Distributed Load:	650 kg/m ² (1200 lbs/yd ²)
Maximum Dynamic Load:	300 kg/m ² (555 lbs/yd ²)

DIN STANDARD 18032 PART II Test Results Harlequin Liberty

	Shock Absorption	Vertical Deformation	Area Deflection	Rolling Load
Requirement	Min 53%	Min 2.3mm	Max 15%	Min 1500 N
Harlequin Liberty	67%	4.1mm	12.8%	> 1500 N

Standards and tests

Harlequin subjects its flooring products to tests by various international authorities covering, for example, physical and acoustic properties, resilience and slip resistance and test information specific to Harlequin floors is available from British Harlequin on request.

All our sprung floors meet the relevant requirements of DIN 18032 part II, which relates principally to sports floors, and we will ensure compliance with the relevant sections of the new EN (European) standard for flooring. However, it must be stressed that no standards exist which relate specifically to dance floors. This was noted by the US-based organisation Entertainment Services Technical Association (ESTA) (www.esta.org) and a Working Group was set up to establish an international standard to be adopted by the American National Standards Institute (ANSI). The Working Group consists of manufacturers, end-users, and specifiers. The Harlequin group is represented by its associate, American Harlequin Corporation.

The new standard will be broadly based on DIN 18032, but modified to reflect the interests of dancers and related stage performers. In June 2006 the initial section in draft form in English and with English terminology was open for public review. The section BSR E1.26, "Recommended Testing Methods and Values for Shock Absorption of Floors Used in Live Performance Venues", relates to shock absorption and has now been adopted as an ANSI standard. A further section BSR E1.34, "Measuring and Specifying the Slipperiness of Floors Used in Live Performance Venues", was submitted for public review in January 2008.

When the new standard is complete there will be incentive for manufacturers to submit products to testing and the Harlequin group is confident of its products meeting the test criteria, which are unattainable by a number of stiffer sports floors.

Note: It cannot be assumed that if a product conforms to this standard it will automatically be approved by dancers, whose predilections vary. The proposed standard will, however, provide protection to specifiers and manufacturers in the form of consensual test data. Please consult Harlequin for guidance before specifying.



HARLEQUIN
The world dances on Harlequin floors®

Sprung Floor Panel System

HARLEQUIN LIBERTY™

Uniclass L84621	EPIC E434
CI/SfB 52 (43) X	

Harlequin Liberty Permanent Sprung Floor Panels

Harlequin Liberty is a relatively “springy” floor, with good area elasticity. The foam blocks compress progressively under light and heavy loads, giving uniform and consistent shock damping and providing the same “feel” and energy return to one or several dancers on the same panel. The pivot joint extends along the panel edges to within 20mm of the corners ensuring the corners are protected from flexion under load and the edges are also carefully supported by elastomer blocks.

Harlequin Liberty panels are available in two versions: portable panels, which can be laid down to create a sprung floor and then taken up and moved to another venue or stored for future use; permanent panels, which have the advantage that they can be taken up and re-installed at another location or used in a different configuration if required.

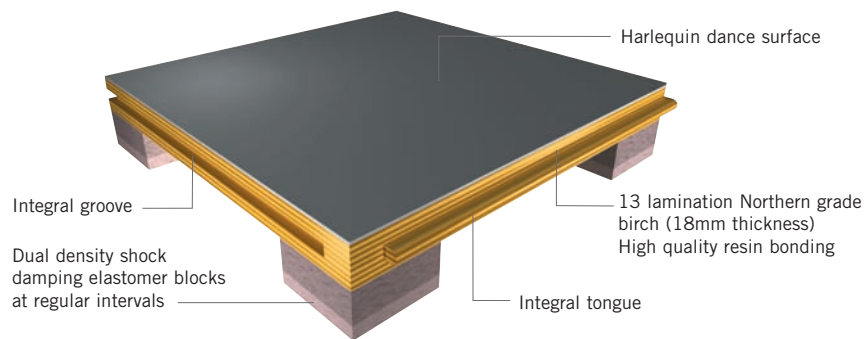

Harlequin Liberty Portable Sprung Floor Panels

A backing is attached to the underside of the portable panels to

- ease sliding of the panels into position
- protect the elastomer blocks
- allow the panels to be stacked more readily.

Edge trim and ramps are available for stage use or where the sprung floor does not extend to the walls of the studio. Harlequin Liberty portable panels are also available with matt black surface for stage use.

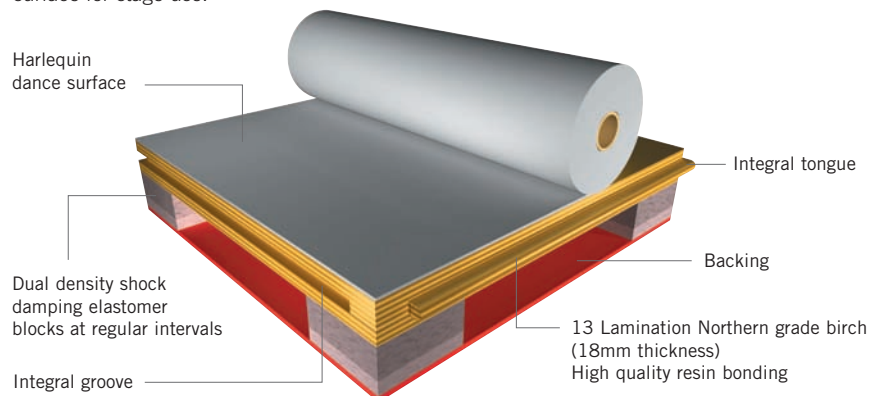

Photography:
Richard Dunkley
Dancers left to right:
Paulin Huguet & Roland Cox
Paulin Huguet & Roland Cox
Ana Lucia Alves
Femi Oyewole



Application Guide - Harlequin's Portable & Permanent Vinyl Floors

✓ Available

	REVERSIBLE	STUDIO	CASCADE	ALLEGRO	TEMPO	FIESTA	STANDFAST	MARINE
Liberty Permanent		✓	✓		✓	✓	✓	✓
Liberty Portable	✓	✓	✓		✓			
Activity		✓	✓	✓	✓	✓	✓	✓
WoodSpring		✓	✓	✓	✓	✓	✓	✓



Cart Specification

Unladen Weight:	115 kg
Capacity:	20 full size or equivalent full and half size panels
Wheels:	Four heavy-duty braked swivel castors with non-marking polyamide rims.

Liberty - Portable Sprung Floor Panels Storage Cart

Harlequin Panel Storage Carts are designed to protect the Liberty panels and provide an easy and safe way of moving them from place to place, whether from stage to scenery dock or on and off vehicles when touring.

Sturdily made of black scratch-resistant powder-coated steel, each cart carries up to 20 full size panels, is fast and easy to load and unload from either side and very easy to manoeuvre. In addition, the cart features forklift pockets for side lifting, if required.



DISTRIBUTOR

04/09/BH001



2.1 Harlequin Liberty
2.1 Harlequin Liberty

HARLEQUIN
The world dances on Harlequin floors®



The Company reserves the right to make any variation in design or construction of the material described.

Harlequin™ and Liberty™ are trademarks of British Harlequin plc, American Harlequin Corporation and Harlequin Europe SA.

Country of origin: Made in the EU © British Harlequin plc, American Harlequin Corporation and Harlequin Europe SA. 2009