



HARLEQUIN

PORTABLE AND PERMANENT SPRUNG FLOOR SYSTEMS

The latest concept in dance floor technology



THE WORLD DANCES ON HARLEQUIN FLOORS °



Contents

- P3 Foreword
- P4 Product overview of Harlequin sprung floor systems and vinyl floors
- P5 - P7 Harlequin LIBERTY™
- P8 Storage of Harlequin LIBERTY™ sprung floor panels
- P9 - P11 Harlequin ACTIVITY™

Dear Friends of Harlequin,

Thank you for your interest in Harlequin sprung floor systems, which for over 30 years have been the choice of the world's artistic and technical directors and dance professionals.

Whether you are a dance company, conservatoire, local school, opera house, theatre or private dance school, Harlequin guarantees you a combination of top-quality products and unbeatable service.

This brochure will help you choose the right floor covering for your requirements. In it you will find technical and practical information on our two sprung floor systems, **Harlequin LIBERTY™** and **Harlequin ACTIVITY™**.

In addition to this brochure on *Portable and permanent sprung floor systems*, we also have a separate brochure on Harlequin vinyl floors.

You can contact our business advisers on the freephone number 00 800 90 69 1000. They will be happy to answer all your questions in your chosen language.



Chantal Lagniau
General Manager, Harlequin Europe



All **Harlequin** floors are guaranteed unconditionally against defects in manufacture, provided that claims are made within six months of the date of delivery (for vinyl floors) or of installation (for Harlequin ACTIVITY™ and LIBERTY™ sprung floor systems).

The company only accepts liability for replacing a product deemed to be defective. **Harlequin** will not accept any liability whatsoever for accidental damage or deterioration linked to inappropriate or extreme use.

Harlequin vinyl and sprung floors are guaranteed for five years from the date of delivery (for vinyl floors) or of installation (for Harlequin ACTIVITY™ and LIBERTY™ sprung floor systems) under normal use and provided that maintenance instructions have been followed.

Harlequin SHOWFLOOR™ and HI-SHINE™ floors are guaranteed for two years only from the date of delivery.



HARLEQUIN

I. Harlequin sprung floors Recommended vinyl floors

Please also see our separate brochure on Harlequin vinyl floors.

	DUO™	STUDIO™	CASCADE™	ALLEGRO™	STANDFAST™	TEMPO™	FIESTA™	HI-SHINE™	SHOWFLOOR™
LIBERTY™ portable version	✓	✓	✓			✓		✓	✓
LIBERTY™ permanent version		✓	✓		✓	✓	✓		
ACTIVITY™		✓	✓		✓	✓	✓		

✓ we recommend

II. Harlequin vinyl floors Recommendations for use

For more information please call us on freephone
00 800 90 69 1000
info@harlequinfloors.com

	CLASSICAL	CONTEMPORARY	JAZZ/AEROBICS	HIP-HOP	TAP	FLAMENCO	THEATRE	EXHIBITIONS	BALLROOM DANCING
DUO™*	••	••	••	••	••	•••	•••	••	•
STUDIO™	•••	•••	•••	••	-	-	-	-	-
CASCADE™	•••	••	••	•	•	••	•••	••	•
STANDFAST™	••	•••	•••	•••	•••	•••	•••	-	•••
ALLEGRO™	••	•••	•••	••	-	-	-	-	-
TEMPO™	•	••	•••	•••	-	-	••	••	•
FIESTA™	-	•	•••	••	•••	••	•••	-	•••
HI-SHINE™	-	••	•	•	•	•	•••	•••	•
SHOWFLOOR™	-	-	-	-	-	-	•••	•••	-

• compatible •• appropriate ••• ideal

* suitable for use on stage in all kinds of performance events



© www.diazwichmann.com

Harlequin LIBERTY™

Portable block-mounted sprung floor system for loose lay or permanent installation

Close-up view of the tongue and groove system and shock-damping blocks of Harlequin LIBERTY™ sprung floors

Harlequin LIBERTY™



Harlequin LIBERTY™

Portable sprung panel system for loose lay or permanent installation

Harlequin LIBERTY™ sprung floors are available in two versions: permanent and portable.

They help to prevent injuries and offer dancers a safe and secure surface on which to work.

Harlequin LIBERTY™ permanent panels offer a unique advantage: they are quick and easy to dismantle and re-install in a different venue or a different configuration

Harlequin LIBERTY™ portable panels are intended for both touring dance companies and entertainment venues where the existing stage floors are too hard for dance and need to be covered with a sprung floor temporarily

Load-bearing capacity

Maximum static load: 454kg/m² (portable panels)

Timber blocks can be fitted underneath the panels to raise the load-bearing capacity to 1,500kg/m² when used with tiered seating.

Maximum dynamic load: 227kg/m² (permanent panels)

When rolling heavy loads 10mm plywood panels should be used on the Liberty floor to spread the load.



Fit your Harlequin LIBERTY™ panels with just one key turn!

- ① The tongue-and-groove panels fit together easily.
- ② The latch system securing the panels locks the panels securely.
- ③ The latch engages with the receiver by turning the locking key.
- ④ One turn of the locking key is all it takes.

Special features of Harlequin LIBERTY™

- The pivot joints and elastomer blocks ensure uniform performance across the entire floor surface, giving dancers the same 'feel' and energy return anywhere on the floor.
- Available in two versions, as portable or permanent panels, **Harlequin LIBERTY™** offers dancers the same level of comfort both in the practice studio and on stage.
- In September 2001, five different sprung floor systems were tested according to DIN standard 18032, part II, specially adapted to the requirements of dancers. **Harlequin LIBERTY™** scored highest with a maximum shock absorption of 67% and an energy return of 20.7% on average.

DIN standard 18032-2 test results for Harlequin LIBERTY™

	Shock absorption	Vertical deformation	Surface deformation	Resistance to rolling loads
Requirements under the standard	Min. 53%	Min. 2.3mm	Max. 15%	Min. 1500N
Harlequin LIBERTY™	67%	4.1mm	12.8%	> 1500N

Harlequin LIBERTY™ portable panels

Harlequin LIBERTY™ permanent panels

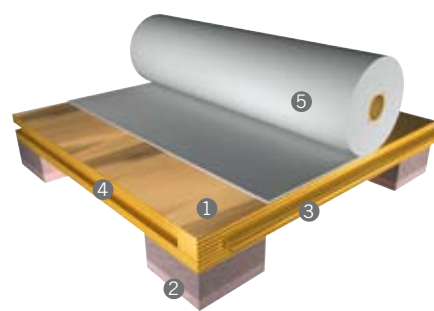
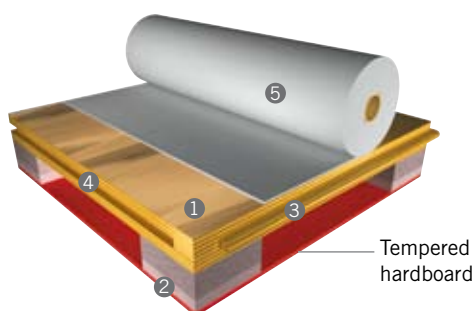

Specifications (both versions)

- ① 18mm birch multi-ply (bonded together with high-quality resin)
- ② Elastomer blocks
- ③ Integral tongue
- ④ Integral groove
- ⑤ Harlequin vinyl dance floor

Panel dimensions:

2m x 1m/full size panel

1m x 1m/half size panel

Weight: 36kg/full size panel

Installed thickness not including dance surface: 42mm

Laying time: 120m² per hour with two people

Panel dimensions:

2m x 1m/full size panel

1m x 1m/half size panel

Weight: 25kg/full size panel

Installed thickness not including dance surface: 37mm

Laying time: 100m² per day with two people. Including perimeter joinery.

- The only technical difference between the permanent and portable versions is the tempered hardboard backing fixed to the underside of the panels to:
 - ease sliding the panels into position
 - protect the elastomer blocks
 - facilitate stacking the panels
- For safety and aesthetic reasons, we recommend fitting ramps or edge trims, specially tailored to the panels, to cover exposed edges (portable panels only).

Configuration of the panels in staggered rows

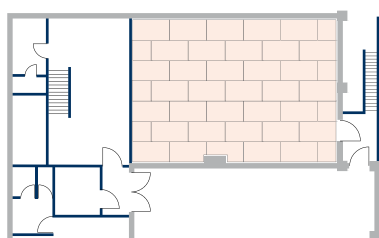

Example of Harlequin LIBERTY™ configuration (can be adapted to suit requirements).

Design and construction

- Panels are made out of birch multi-ply.
- Each panel is fitted with dual density shock-damping elastomer blocks to ensure uniform, consistent shock absorption. Tested using the Shore Durometer Test, the dual density enables the blocks to compress gradually, providing exactly the same degree of shock absorption and energy return to one or more dancers on the same panel.
- The panels are laid in brickwork fashion (i.e. staggered rows) so that the joints don't coincide, and are linked to each other by tongue-and-groove joints.
- The tongues stop 20mm from the corners, making the floor more resistant to heavy loads.
- The edges of the panels are supported by elastomer blocks.



Harlequin LIBERTY™ storage cart

Harlequin LIBERTY™ sprung floor panel storage carts are specially designed to protect the panels and provide a safe way of moving them from stage to scenery dock.

Made out of tough, black, scratch-resistant, powder-coated steel, each cart is mounted on four swivel wheels with non-marking rims, fitted with brakes.

The front gate of the cart is detachable and the two sides hinge back fully to allow access to the cart on three sides. The panels are stacked in fives onto support bars to avoid crushing the panels underneath. Once the cart is fully loaded, the sides are hinged back and the front gate is replaced and locked into position.

Each cart can hold up to 20 full size panels, with half size panels loaded side by side. There is a removable storage box at the base of each cart for ramps and accessories. In addition, there are two fork pockets under the cart, making it easy to manoeuvre with a fork-lift truck.

Storage cart with removable front gate



Unladen weight:	350kg
Dimensions:	2.21m (L) – 1.18m (W) – 1.44m (H)
Capacity:	20 full size panels or equivalent full and half size panels
Wheels:	4 swivel wheels, all of them braked
Wheel diameter:	152mm

The new transport cart for Harlequin LIBERTY™



Harlequin LIBERTY™ transport cart

Harlequin LIBERTY™ sprung floor panel transport carts are specially designed to fully protect the panels, edge trims and ramps during transport on tour.

Made out of tough, black, scratch-resistant, powder-coated steel, each cart is mounted on four swivel wheels with non-marking rims and fitted with brakes, making it easy to manoeuvre.

Each cart can transport up to 20 full-size panels which can be loaded and unloaded extremely quickly. The sides of the carts have slots for fork-lift trucks, making them easy to handle.

Unladen weight:	130kg
Dimensions:	2.03m (L) – 1,27m (W) – 1.26m (H)
Capacity:	20 full-size or 40 half-size panels
Wheels:	4 swivel-braked wheels
Wheel diameter:	152mm



© David Laurent

Harlequin ACTIVITY™

A fully floating sprung floor for permanent installation

The second layer of semi-flexible panels

Harlequin ACTIVITY™



Harlequin ACTIVITY™

A fully floating sprung floor for permanent installation

Harlequin ACTIVITY™ is a permanently installed sprung floor system based on the now well-established 'triple sandwich' construction originated by Harlequin over 25 years ago. The fully floating construction is not fixed to the floor or walls, thus minimising noise transmission.

Harlequin ACTIVITY™ has been tested for noise reduction with a variety of Harlequin dance surfaces in accordance with standard BS EN ISO 140-8:1998. The results showed that **Harlequin ACTIVITY™** achieves significant impact sound reduction.

Load-bearing capacity

Maximum static load: 750kg/m²

Timber blocks can be fitted underneath the panels to raise the load-bearing capacity to 1,500kg/m² when used with tiered seating.

Special features of Harlequin ACTIVITY™

- Uniform performance across the entire floor surface.
- Remarkable acoustic properties: achieves significant impact sound reduction (test results ranging from 22 to 24dB).
A BS EN ISO 140-8:1998 test report is available from Harlequin on request.
- Very good value for money
- Conforms to DIN 18032 standard, part II.

DIN standard 18032-2 test results for Harlequin ACTIVITY™

	Shock absorption	Vertical deformation	Surface deformation	Resistance to rolling loads
Requirements under the standard	Min. 53%	Min. 2.3mm	Max. 15%	Min. 1500N
Harlequin ACTIVITY™	59.6%	3.8mm	7.2%	> 1500N

Harlequin ACTIVITY™ with vinyl surface

Harlequin ACTIVITY™ with hardwood surface

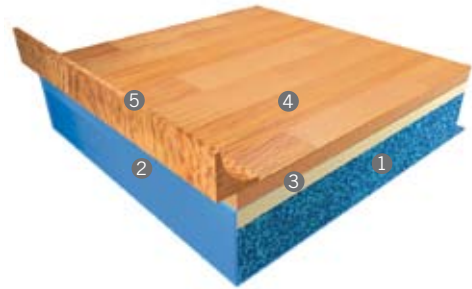
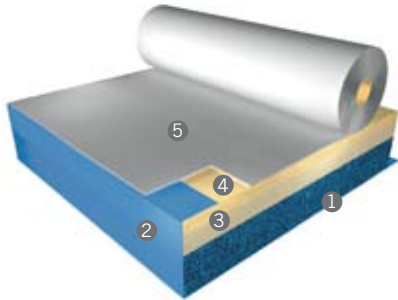

Specifications (both versions)

Conforms to DIN 18032 standard, part II

- ① Cellular polyurethane
- ② Damp-proof membrane

Laying time: a floor of 100-150m² can generally be laid in five days (by two people)

- ③ Lower semi-flexible panel
- ④ Top semi-flexible panel
- ⑤ Performance surface

Weight: 19.5kg/m² (not including performance surface)

Overall thickness: 46mm (not including performance surface)

- ③ Semi-flexible support layer
- ④ Engineered board with choice of oak, beech or maple hardwood wear layer
- ⑤ Matching hardwood scotia edging

Weight: 22kg/m²

Overall thickness: 51mm



- ① Cellular polyurethane
- ② First layer of semi-flexible panels
- ③ Second layer of semi-flexible panels laid at right angles to the first layer in staggered rows
- ④ Harlequin performance surface

Design and construction

The following layers are applied to a smooth, dry concrete sub-floor:

- Polymer damp-proof membrane.
- Cellular polyurethane 25mm thick and tested for resilience by Harlequin.
- Layer of semi-flexible panels 12mm thick.
- Second layer of semi-flexible panels 9mm thick installed at right angles and in staggered rows.
- Second layer of semi-flexible panels 9mm thick installed at right angles and in staggered rows.
- Performance surface 2 or 3mm thick and weighing between 2.3 and 2.6kg/m², adhered and welded to the surface
- Maximum overall height is 49mm, including the performance surface.



Harlequin Europe SA
 29, rue Notre-Dame
 L-2240 Luxembourg
 Tel. +352 46 44 22
 Fax +352 46 44 40
 Freephone 00 800 90 69 1000
www.harlequinfloors.com
info@harlequinfloors.com

British Harlequin plc
 Tel.: +44 (0)1892 514 888
 Fax: +44 (0)1892 514 222
enquiries@harlequinfloors.com

American Harlequin Corporation
 Tel.: +1 856 234 55 05
 Fax: +1 856 231 4403
dance@harlequinfloors.com

Harlequin Australasia Ply Ltd
 Tel.: +61 (2) 9869 4566
 Fax: +61 (2) 9869 4547
contact@harlequinfloors.com

Harlequin Asia Limited
 Tel: +852 254 11 666
 Fax: +852 254 11 999
hksales@harlequinfloors.com

LUXEMBOURG
 LONDON
 LOS ANGELES
 PHILADELPHIA
 FORT WORTH
 SYDNEY
 PARIS
 HONG KONG
 MADRID



Mixed Sources
 Product group from well-managed
 forests and other controlled sources
 Cert no. EIR-COC-051203
www.fsc.org
 © 1996 Forest Stewardship Council